

## WIRE MESH WALL PANEL SYSTEM (AC-770)

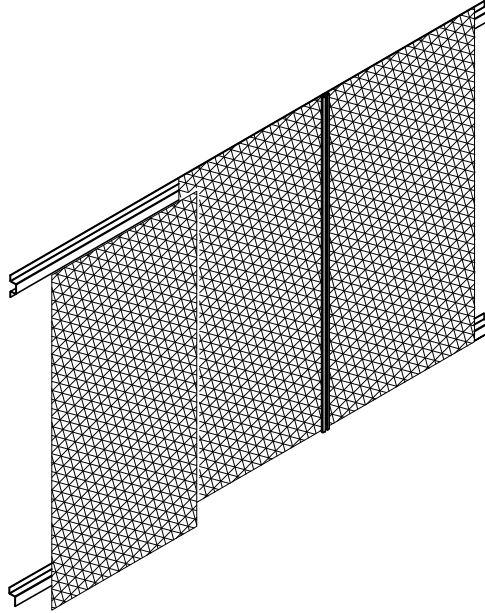

- Description:** Wire Mesh Wall Panel System. Wire mesh panel, directly mounted to horizontal hat channel with screws, and at perimeter covered with extruded aluminum trim, finish to match panels. Efficient and quick installation.
- Application:** Flat and curved wall system application available
- Material:** Panels are available in aluminum, steel or stainless steel.
- Finishes:** Natural, bright, copper and painted finishes.
- Standard Sizes:** Maximum size 4'-0" X 10'-0"
- Fire Rating:** Class A
- Recycled content:** Aluminum alloys 32% (5052) - 66% (3105)

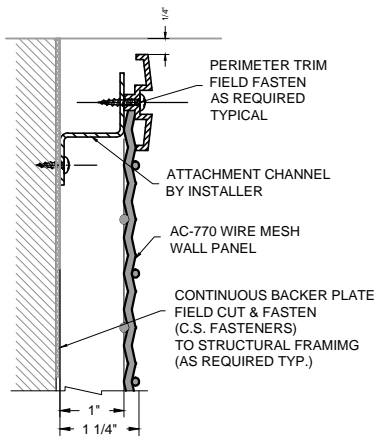

**1** PERIMETER DETAIL (TOP)  
AC-770-FT1

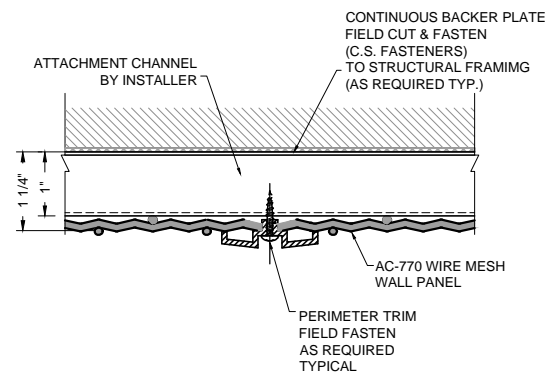

**2** PANEL JOINT DETAIL  
AC-770-FS1

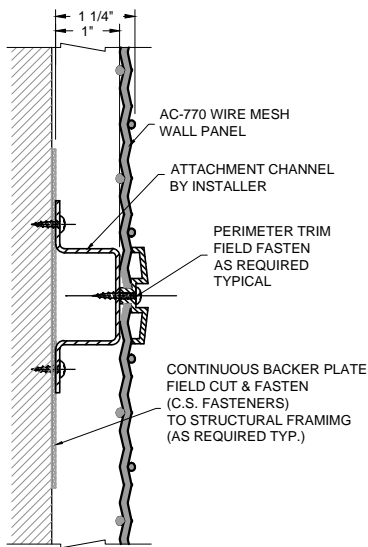

**3** PANEL JOINT DETAIL  
AC-770-FM1

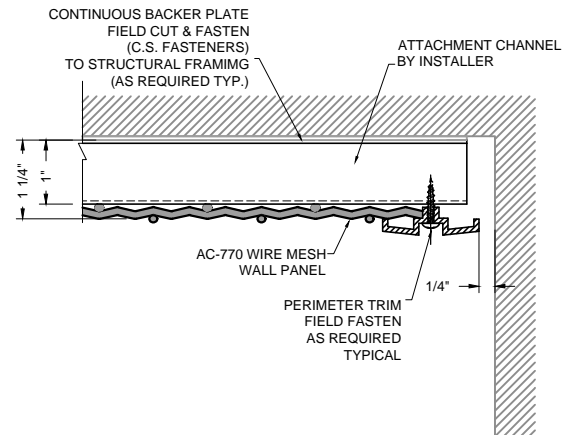

**4** PERIMETER DETAIL (EDGE)  
AC-770-FE1

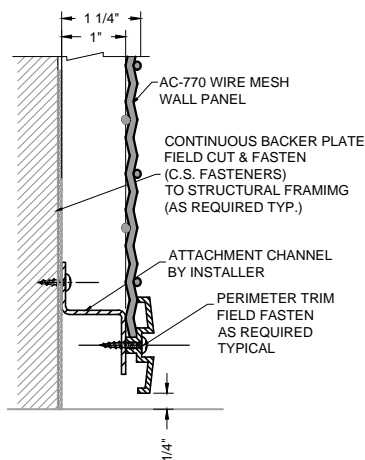

**5** PERIMETER DETAIL (BASE)  
AC-770-FB1