

accent[®]

CEILING AND WALLS

A DIVISION OF ADAMS CAMPBELL COMPANY
ISO 9001: 2000 CERTIFIED

TORSION SPRING MOUNTED CEILING SYSTEM (Surewood AC-440C)

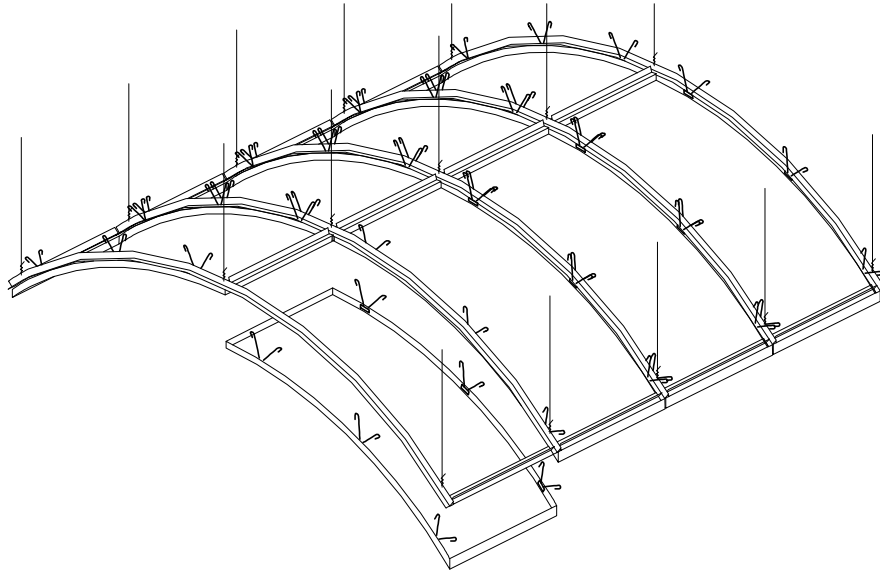

PATENT PENDING # 11 / 359 / 316

- Description:** Real wood veneer finish, concealed torsion spring mounting system creates a clean monolithic appearance. Butt joint and reveal joints available, Perforated and Non-Perforated. Concealed heavy-duty tee bar grid system supports each panel. Each individual panel can be removed without disturbing adjacent panels.
- Application:** Ceiling provided for curving interior installation. (See AC-440F for flat application)
- Material:** Aluminum / Real Wood Veneer
- Finishes:** Real wood veneer include Maple, Birch, Ash, Cherry and Oak
Reference Options tab for additional finishes available.
- Standard Sizes:** 24" x 24", 24" x 48", 30" x 30", 36" x 36", 36" x 60", 30" x 72", 30" x 96" and 48" x 48". Custom sized and shaped panels also available.
- Fire Rating:** Class A
- Acoustics:** NRC rating of .70 to 1.00 can be achieved by selecting correct perforation pattern and acoustical backing.
- Perforation:** Reference Options Tab for Patterns, consult manufacturer for acoustical values
- Recycled content:** Aluminum alloys - 32% (5052) - 66% (3105)

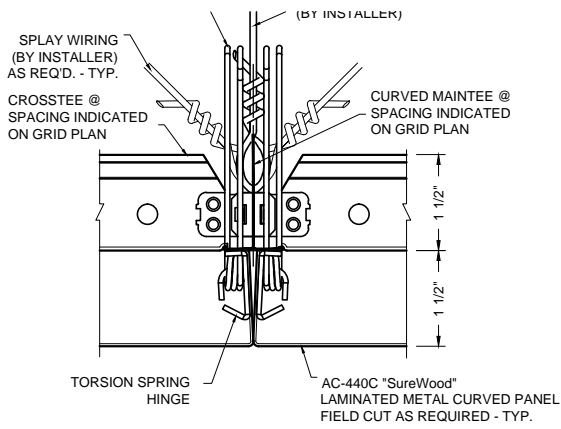

1 PANEL JOINT DETAIL
AC-440C-PJ1

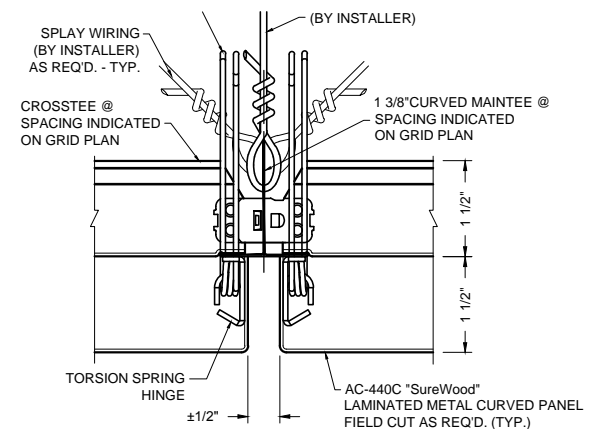

2 PANEL JOINT DETAIL
AC-440C-PJ2

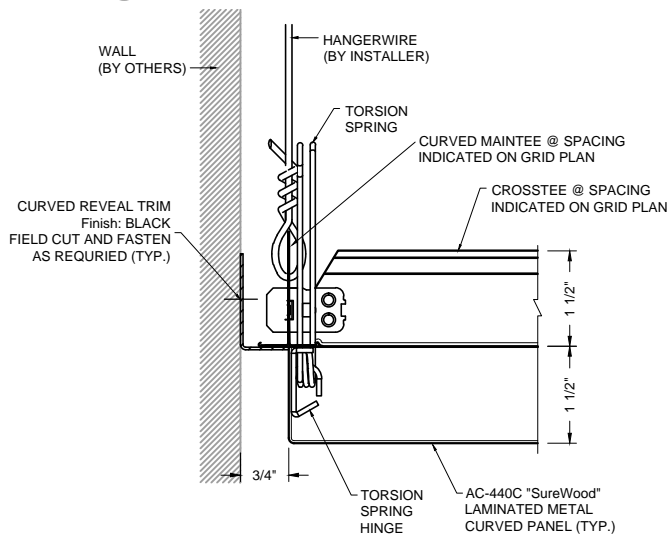

3 PERIMETER DETAIL
AC-440C-P2

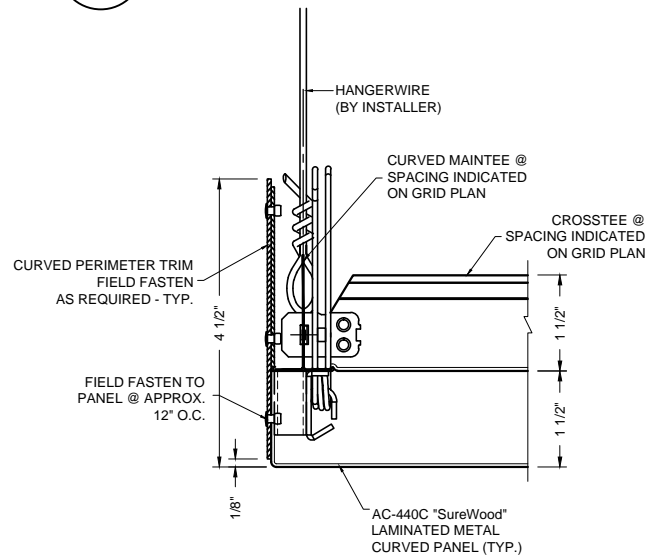

4 PERIMETER DETAIL
AC-440C-P4

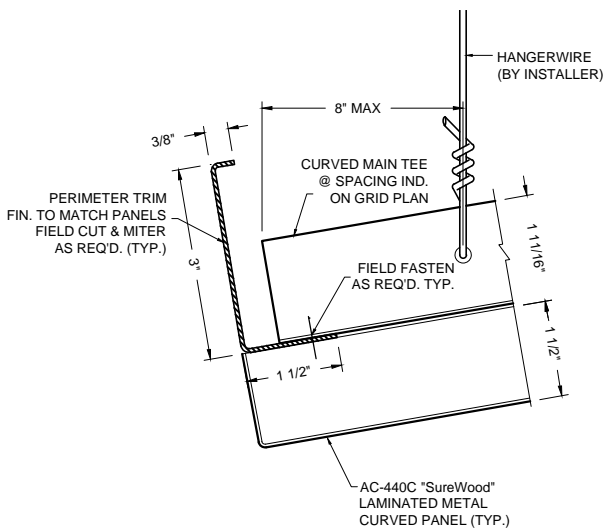

5 PERIMETER DETAIL
AC-440C-P5

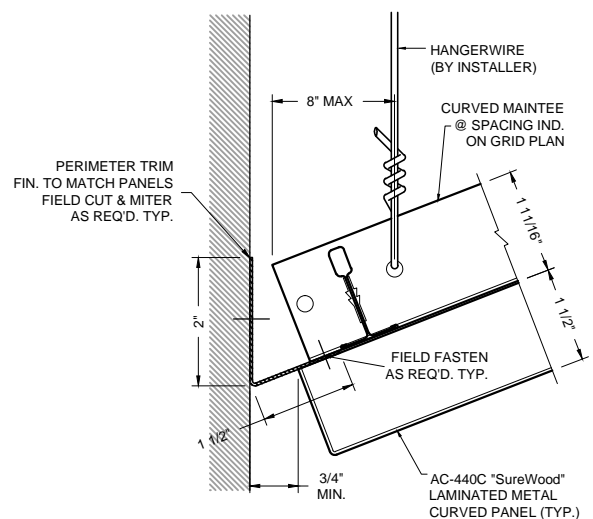

6 PERIMETER DETAIL
AC-440C-P6

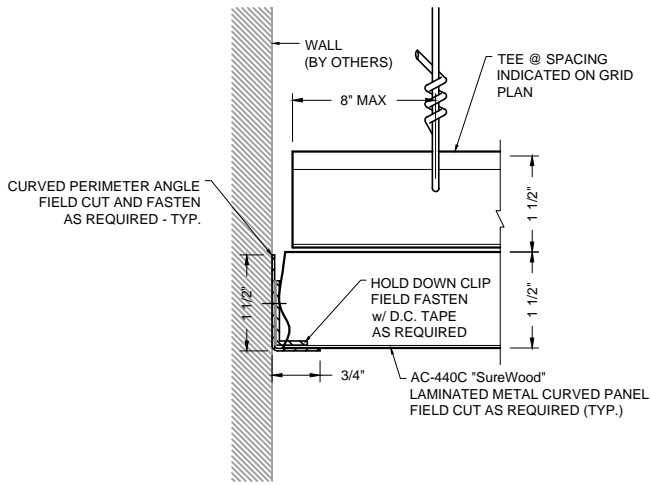

1 PERIMETER DETAIL
AC-440C-PFC1

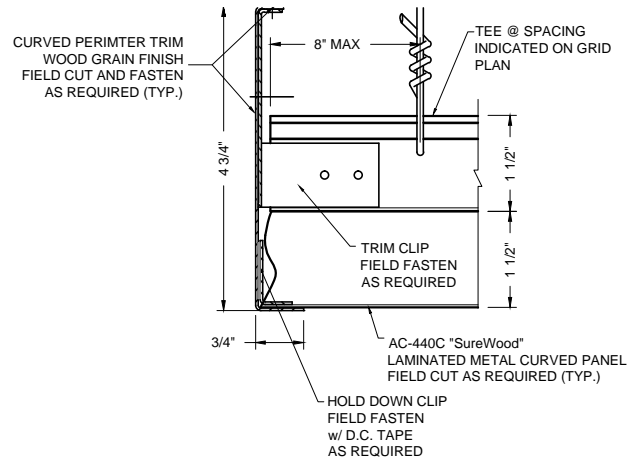

2 PERIMETER DETAIL
AC-440C-PFC2

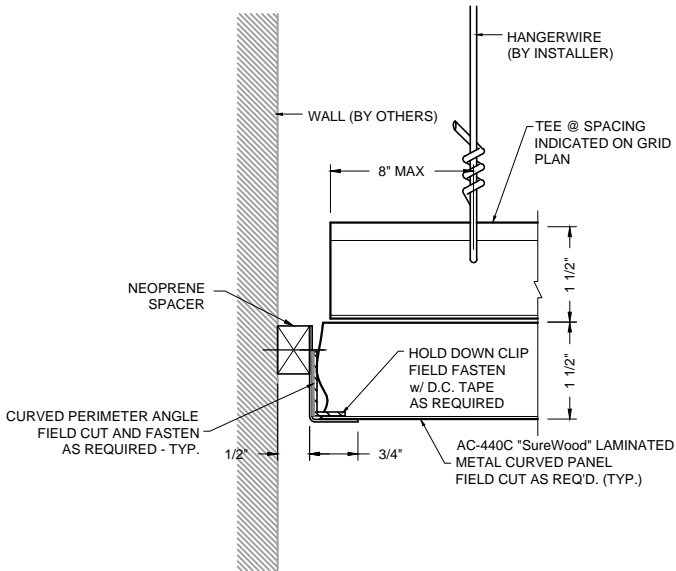

3 PERIMETER DETAIL
AC-440C-PFC3

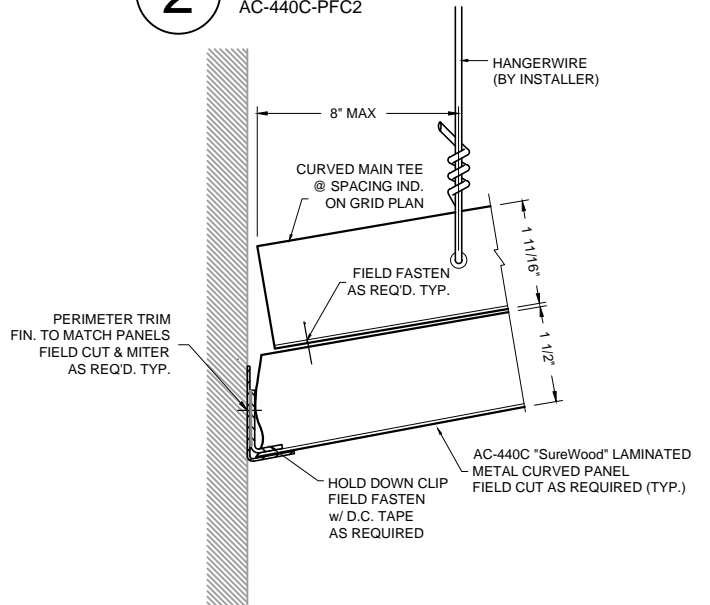

4 PERIMETER DETAIL
AC-440C-PFC4