

accent[®]

CEILING AND WALLS

A DIVISION OF ADAMS CAMPBELL COMPANY
ISO 9001: 2000 CERTIFIED

TORSION SPRING MOUNTED CEILING SYSTEM (Envirowood AC-430C)

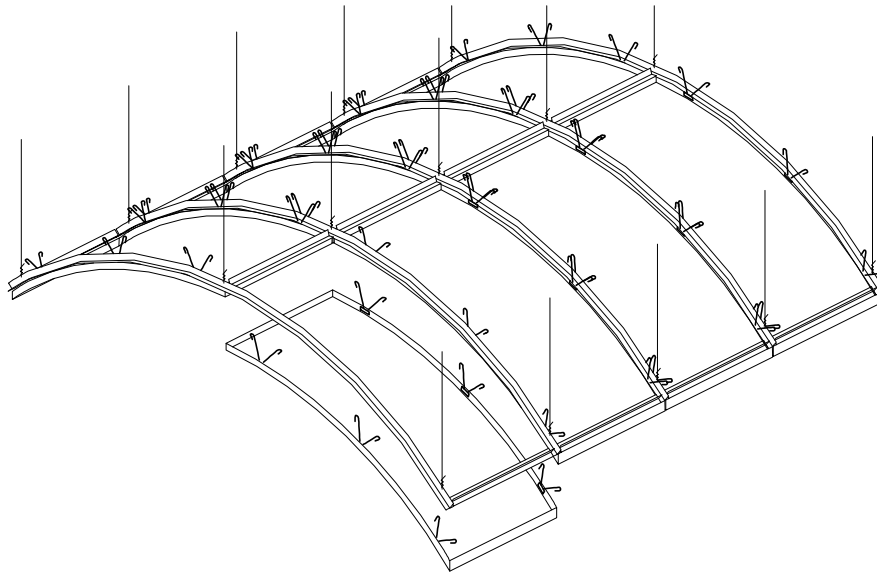

- Description:** Simulated wood grain finish, concealed torsion spring mounting system creates a clean monolithic appearance. Butt joint and reveal joints available, Perforated and Non-Perforated.
Concealed heavy-duty tee bar grid system supports each panel.
Each individual panel can be removed without disturbing adjacent panels.
- Application:** Ceiling provided for curving interior installation. (See AC-430F for flat application)
- Material:** Aluminum / Vinyl Veneer
- Finishes:** Standard simulated wood grain veneers include Maple, Oak and Cherry
Reference Options tab for additional finishes available.
- Standard Sizes:** 24" x 24", 24" x 48", 30" x 30", 36" x 36", 36" x 60", 30" x 72", 30" x 96"
and 48" x 48". Custom sized and shaped panels also available.
- Fire Rating:** Class A
- Acoustics:** NRC rating of .70 to 1.00 can be achieved by selecting correct perforation pattern and acoustical backing.
- Perforation:** Reference Options Tab for Patterns, consult manufacturer for acoustical values
- Recycled content:** Aluminum alloys - 32% (5052) - 66% (3105)

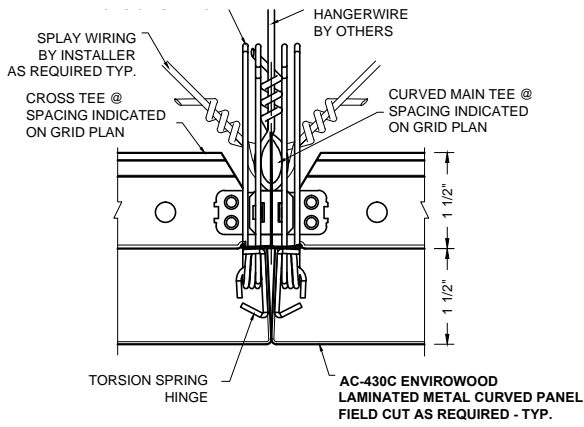

1 PANEL JOINT DETAIL
AC-430C-PJ1

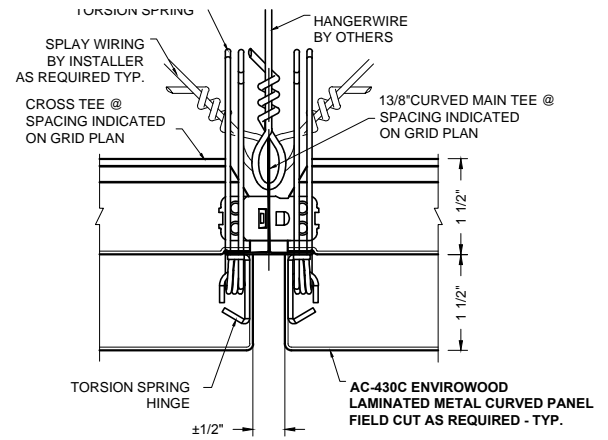

2 PANEL JOINT DETAIL
AC-430C-PJ2

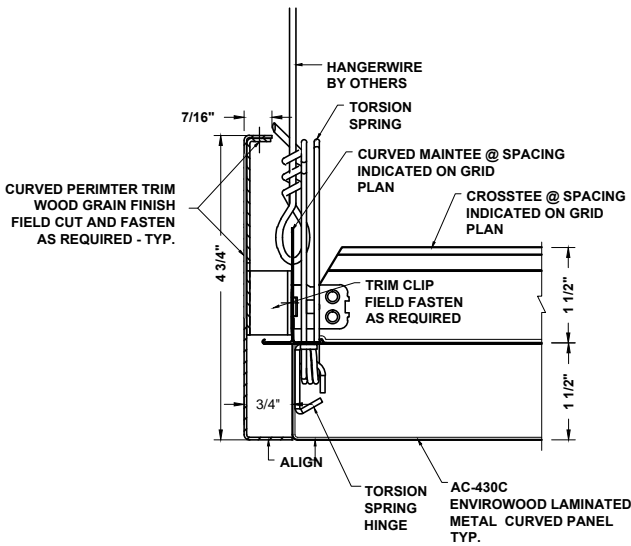

3 PERIMETER DETAIL
AC-430C-P1

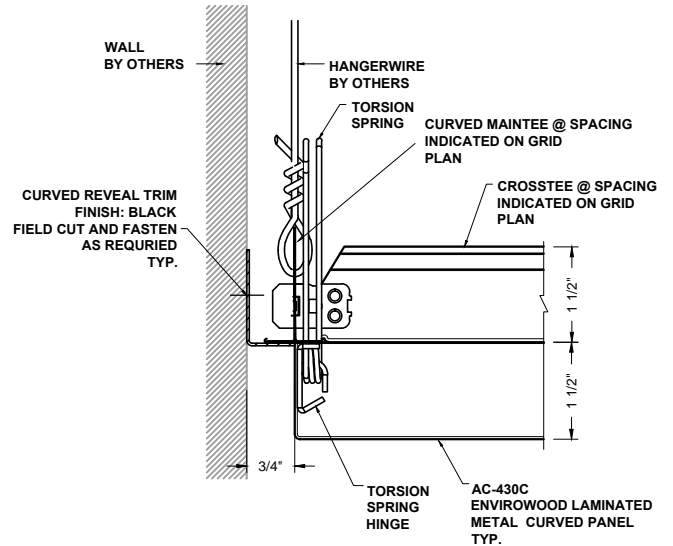

4 PERIMETER DETAIL
AC-430C-P2

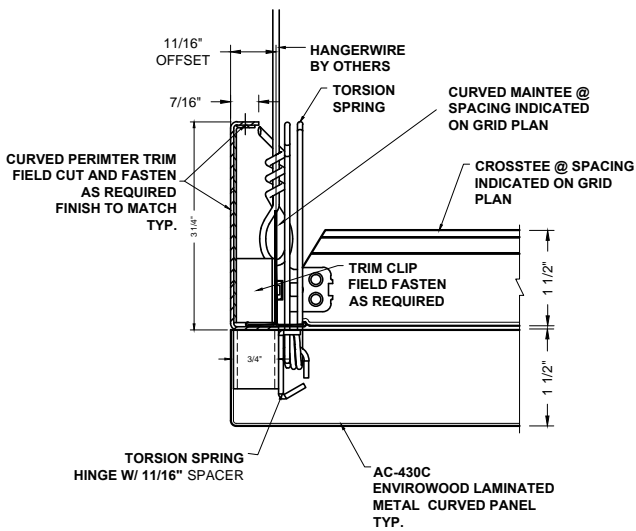

5 PERIMETER DETAIL
AC-430C-P3

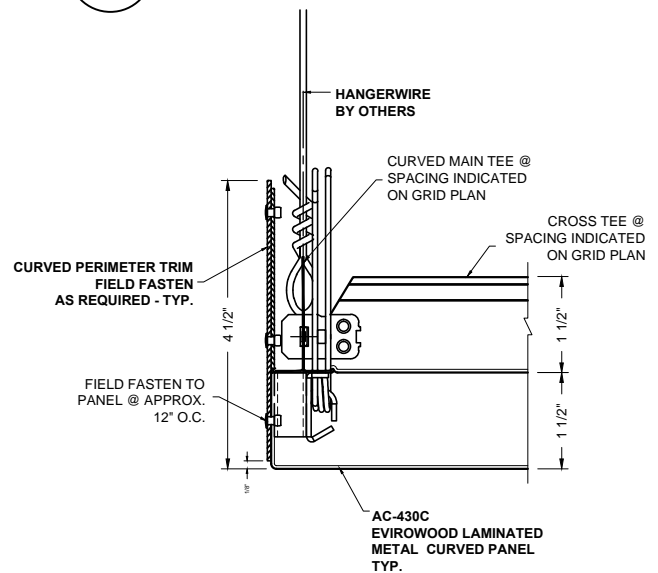

6 PERIMETER DETAIL
AC-430C-P4

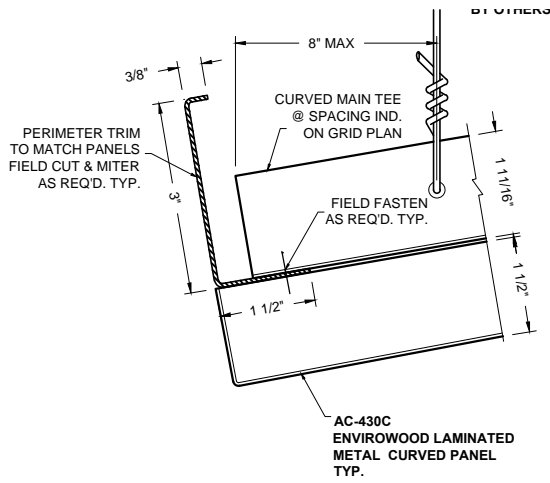

1 PERIMETER DETAIL
AC-430C-P5

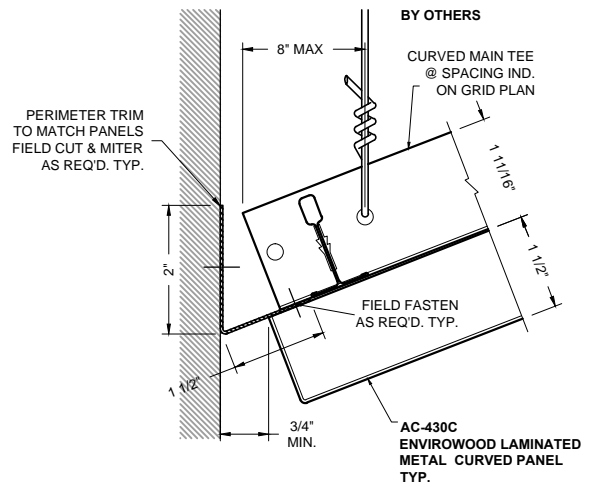

2 PERIMETER DETAIL
AC-430C-P6

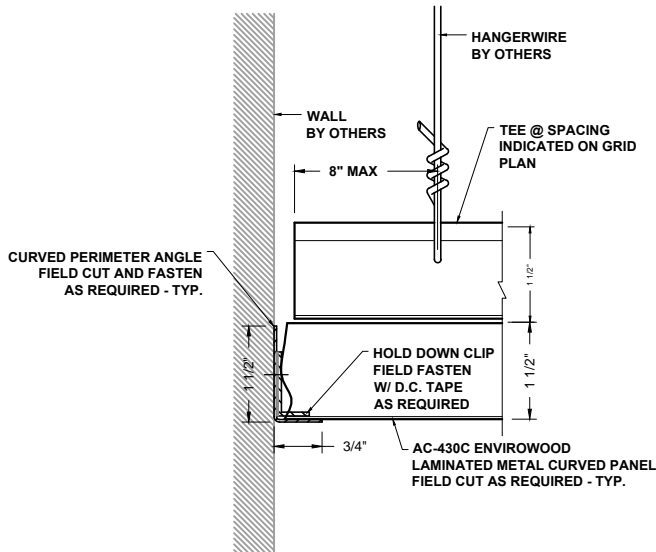

3 PERIMETER DETAIL
AC-430C-PFC1

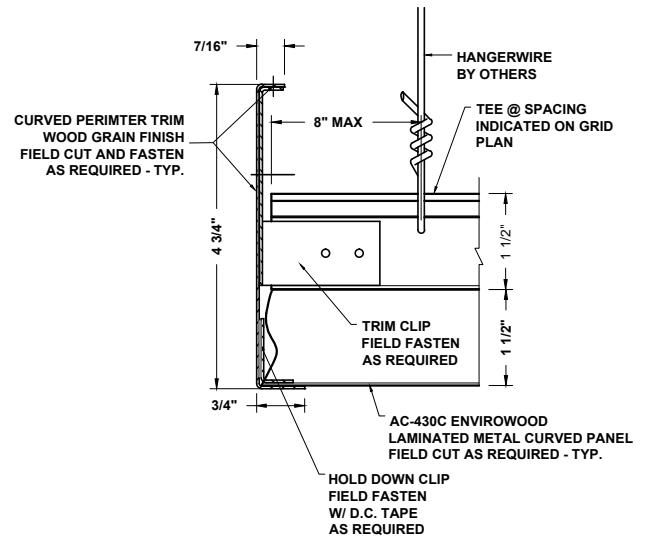

4 PERIMETER DETAIL
AC-430C-PFC2

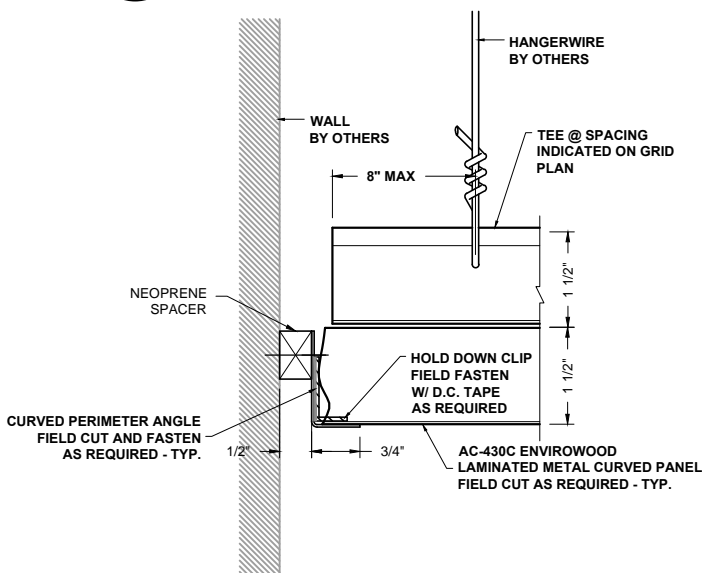

5 PERIMETER DETAIL
AC-430C-PFC3

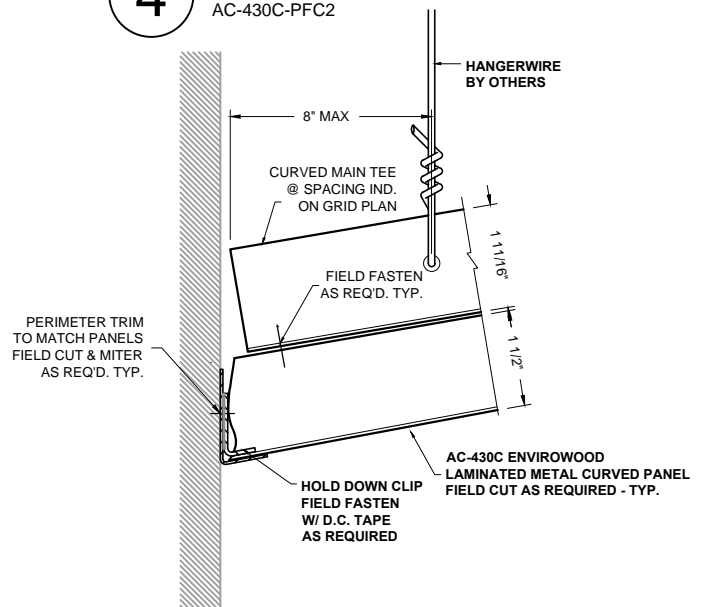

6 PERIMETER DETAIL
AC-430C-PFC4