

accent
CEILINGS AND WALLS
A DIVISION OF ADAMS CAMPBELL COMPANY
ISO 9001: 2000 CERTIFIED

METAL ZEE TRACK MOUNTED WALL PANEL SYSTEM (SureWood AC-740)

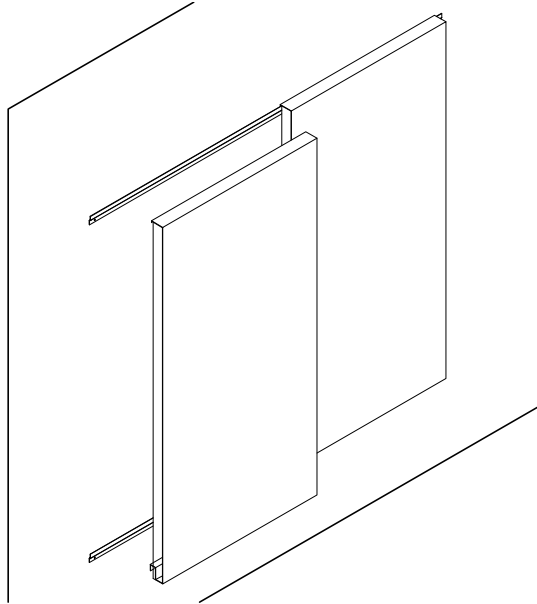

- Description:** Real wood veneer facing eliminates cost and wrapping issues of a real wood wall panel. Panels are mounted to concealed zee track mounted to wall or ridged backer. A 1/16" wide reveal condition at all panel joints, Perforated or Non-Perforated. Perimeter trim available for field cut conditions.
- Application:** Wall panel provided for interior installation. Curved application available.
- Material:** Panels are aluminum with real wood facing laminated to face of panel.
- Finishes:** Real wood veneer facing include Maple, Birch, Ash, Cherry and Oak Reference Options tab for additional finishes available.
- Standard Sizes:** Maximum size 3'-6" x 10'-0"
- Fire Rating:** Class A
- Acoustics:** NRC rating of .70 to 1.00 can be achieved by selecting correct perforation pattern and acoustical backing.
- Perforation:** Reference Options Tab for Patterns, consult manufacturer for acoustical values
- Recycled content:** Aluminum alloys 32% (5052) - 66% (3105)

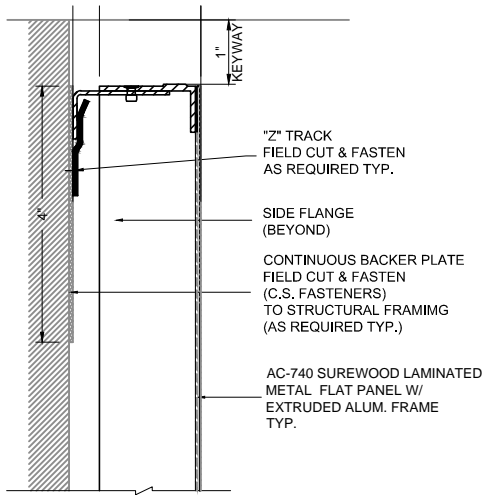

1 PERIMETER DETAIL (TOP)
AC-740-FT1

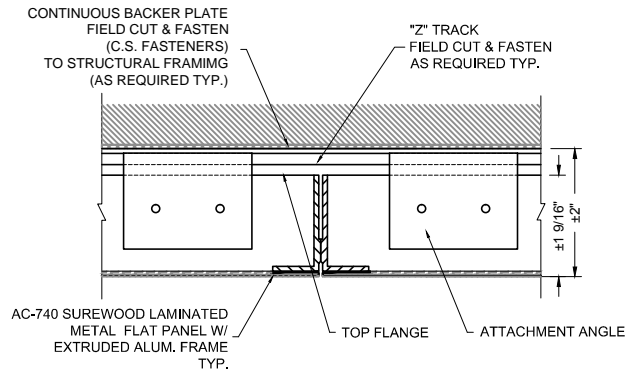

2 PANEL JOINT DETAIL
AC-740-FS1

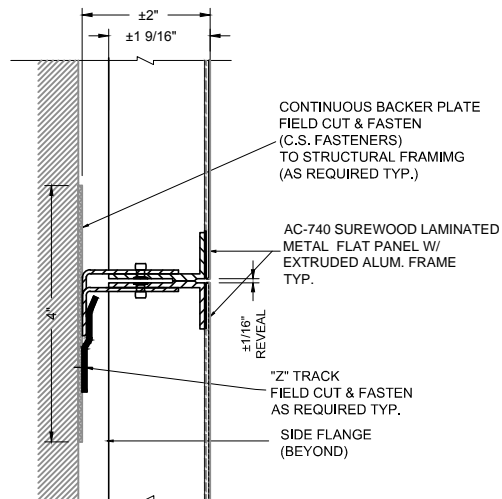

3 PANEL JOINT DETAIL
AC-740-FM1

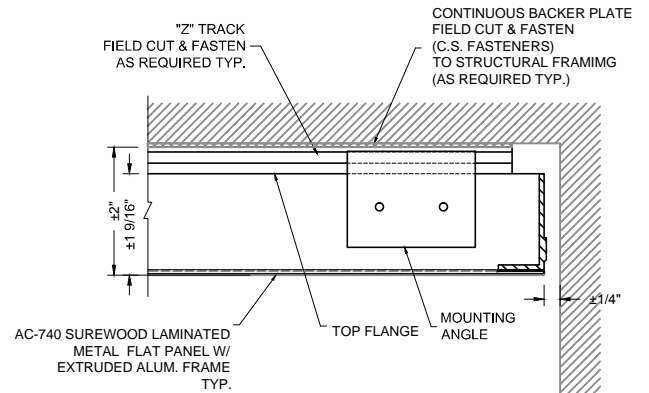

4 PERIMETER DETAIL
AC-740-FE1

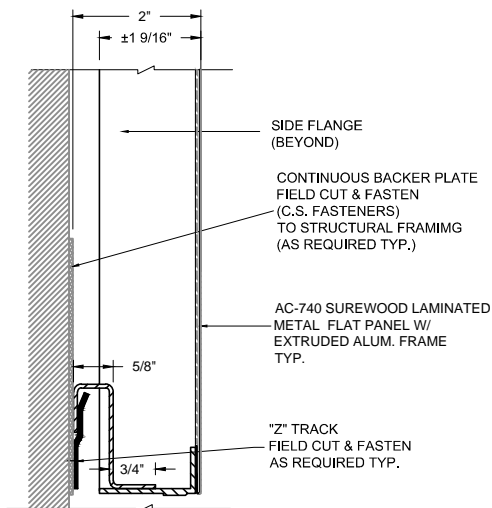

5 PERIMETER DETAIL (BASE)
AC-740-FB1