

accent

CEILING AND WALLS
A DIVISION OF ADAMS CAMPBELL COMPANY
ISO 9001: 2000 CERTIFIED

TORSION SPRING MOUNTED CEILING SYSTEM (AC-410C)

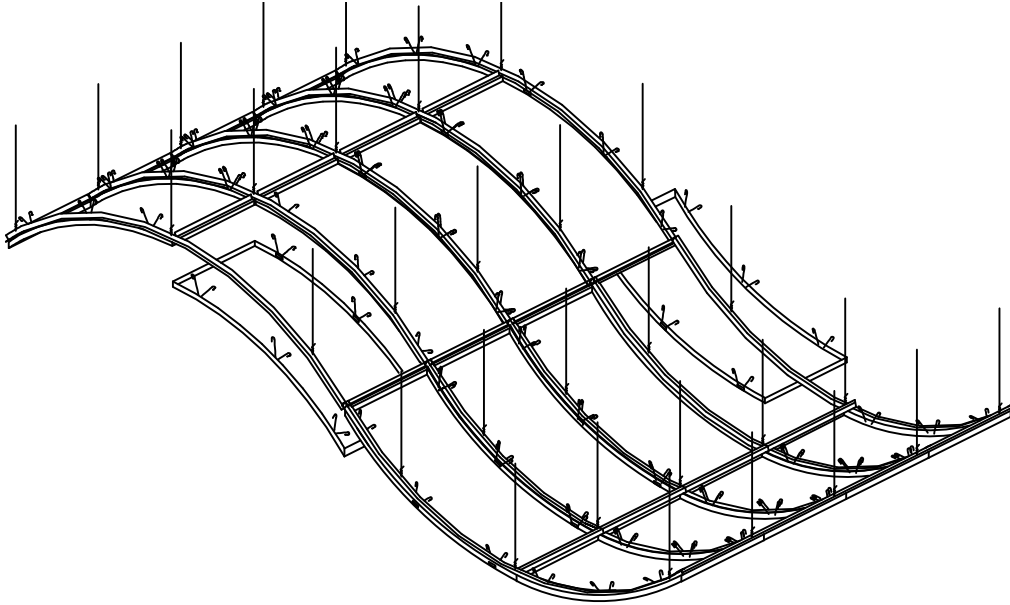

- Description:** Concealed torsion spring mounting system creates a clean monolithic appearance. Butt joint and reveal joints available, Perforated and Non-Perforated concealed heavy-duty tee bar grid system supports each panel. Each individual panel can be removed without disturbing adjacent panels.
- Application:** Ceiling provided for interior installation. (See AC-410EXT for exterior application)
- Material:** Panels are available in aluminum, steel or stainless steel.
- Finishes:** Anodized, brushed and bright finish. Painted powder coat colors. Reference Options tab for available finishes.
- Standard Sizes:** 24" x 24", 24" x 48", 30" x 30", 36" x 36", 36" x 60", 30" x 72", 30" x 96" and 48" x 48". Custom sized and shaped panels also available.
- Fire Rating:** Class A
- Acoustics:** NRC rating of .70 to 1.00 can be achieved by selecting correct perforation pattern and acoustical backing.
- Perforation:** Reference Options Tab for Patterns, consult manufacturer for acoustical values
- Recycled content:** Aluminum alloys - 32% (5052) - 66% (3105)

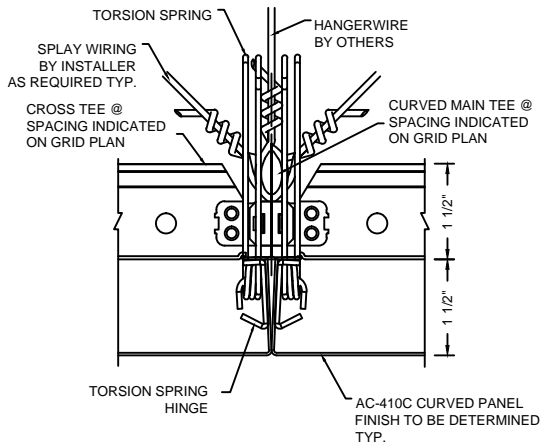

1 PANEL JOINT DETAIL
AC-410C-PJ1

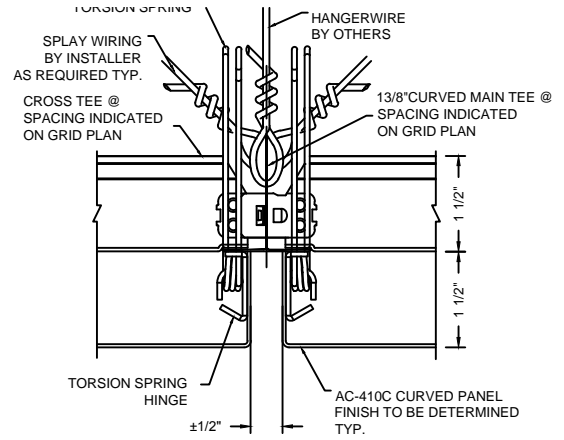

2 PANEL JOINT DETAIL
AC-410C-PJ2

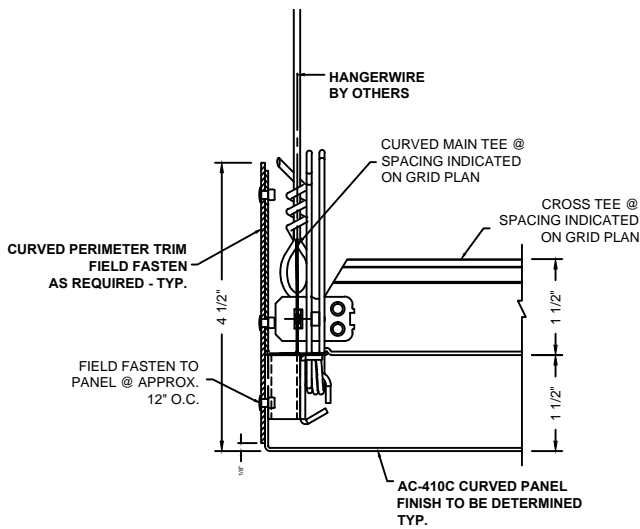

3 PERIMETER DETAIL
AC-410C-P4

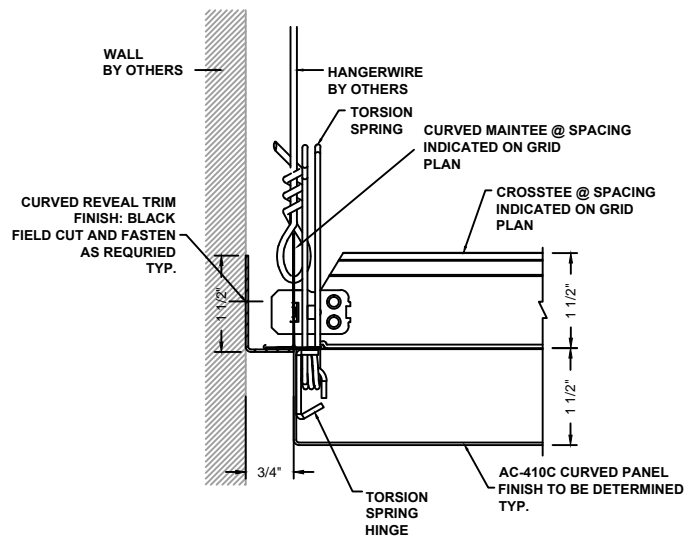

4 PERIMETER DETAIL
AC-410C-P2

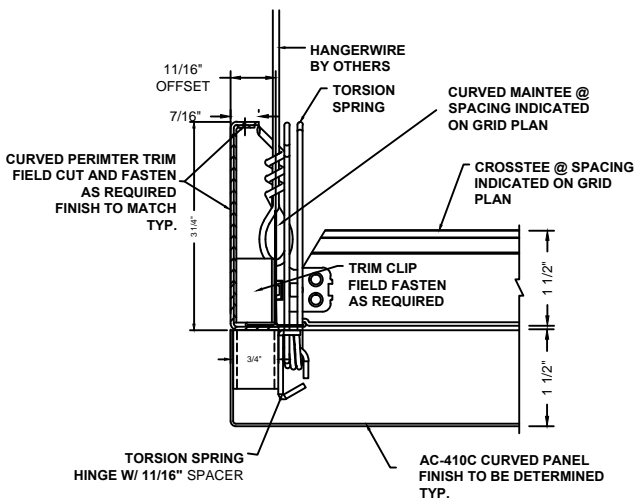

5 PERIMETER DETAIL
AC-410C-P3

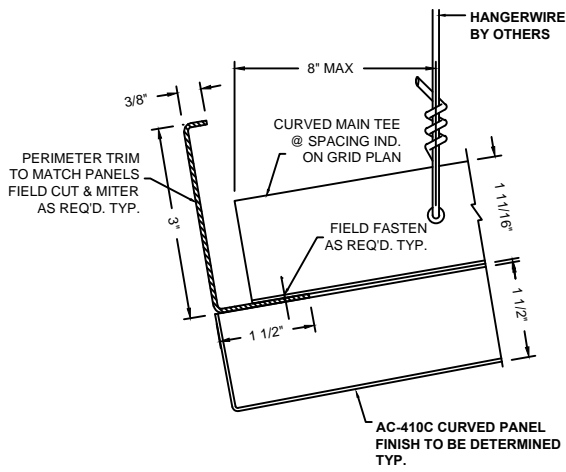

1 PERIMETER DETAIL
AC-410C-P5

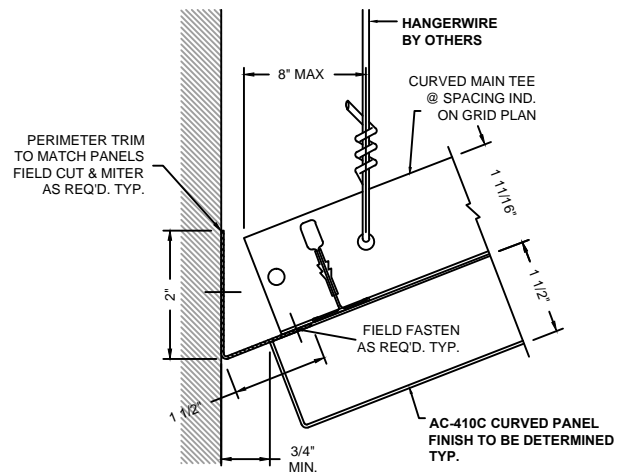

2 PERIMETER DETAIL
AC-410C-P6

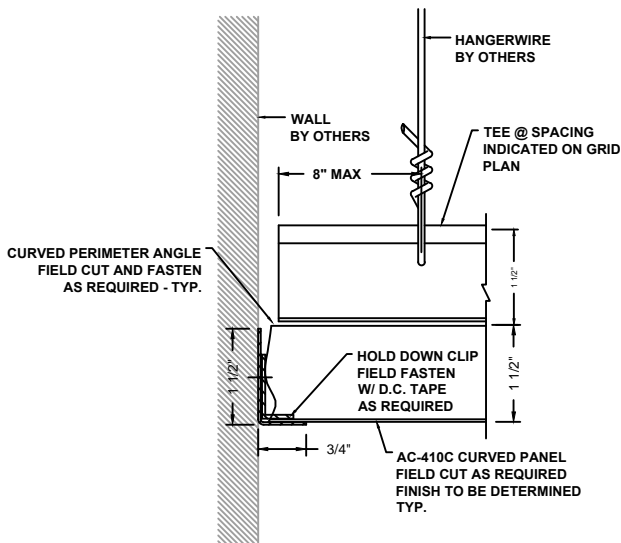

3 PERIMETER DETAIL
AC-410C-PFC1

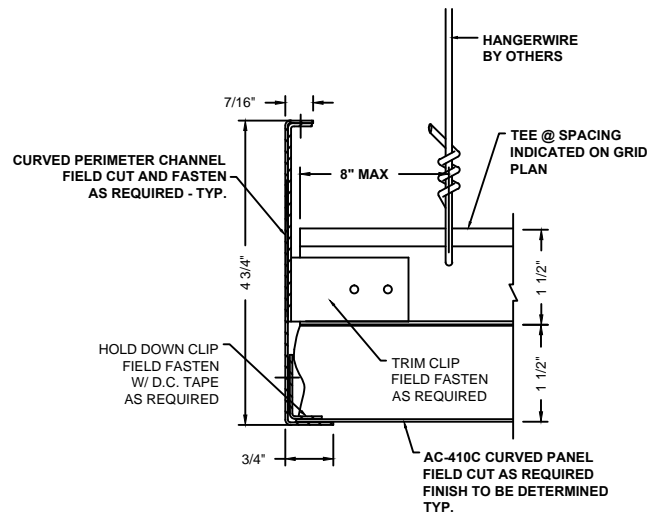

4 PERIMETER DETAIL
AC-410C-PFC2

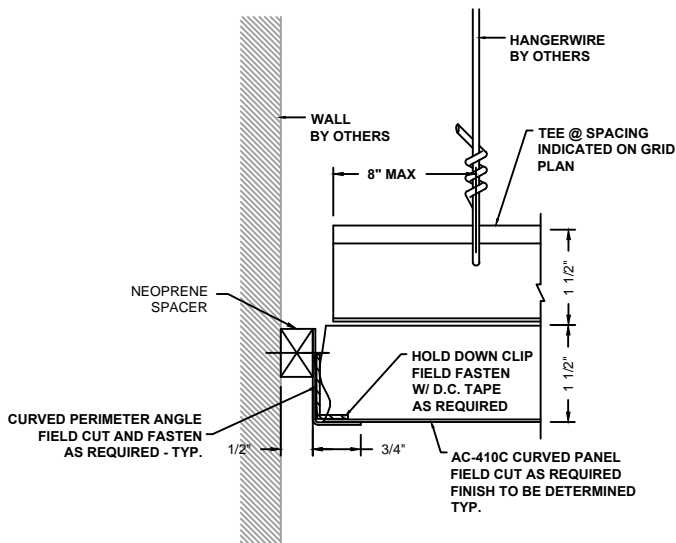

5 PERIMETER DETAIL
AC-410C-PFC3

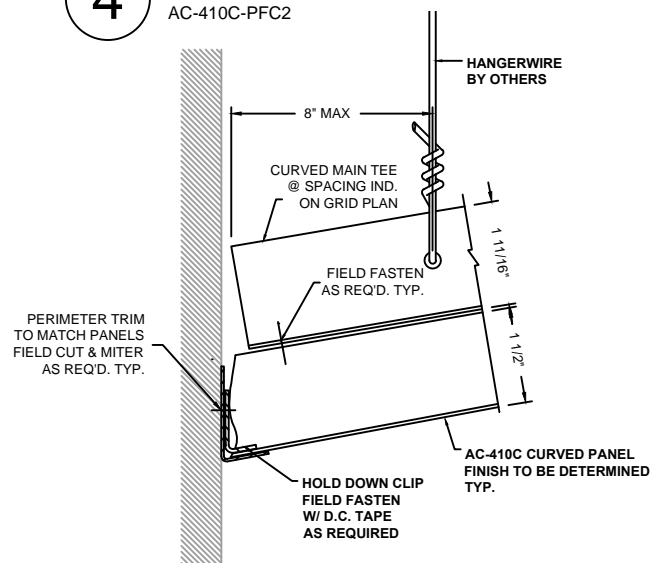

6 PERIMETER DETAIL
AC-410C-PFC4