

# accent<sup>®</sup>

## CEILING S AND WALLS

A DIVISION OF ADAMS CAMPBELL COMPANY  
ISO 9001: 2000 CERTIFIED

### LAY-IN FLAT METAL CEILING SYSTEM (AC-110F)

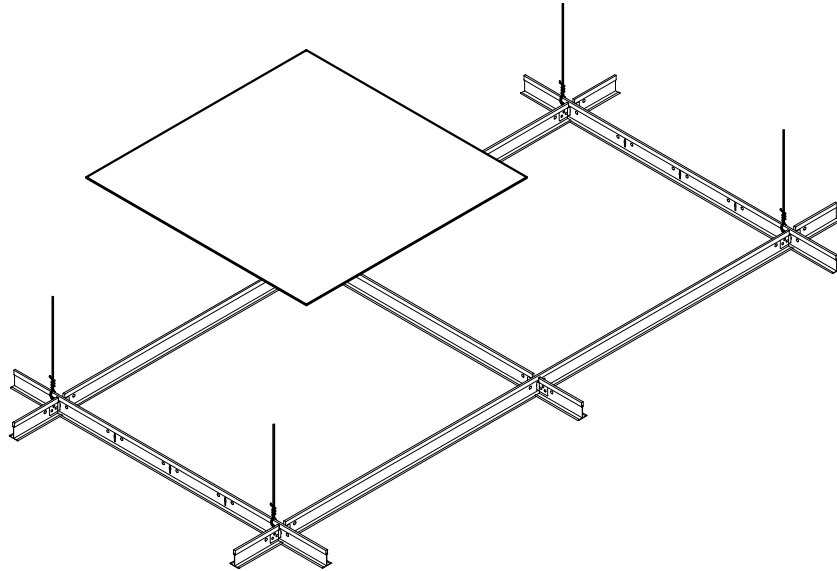

- Description:** Economical lay-in ceiling system Perforated or Non-Perforated. Exposed, standard grid system. Flat sheet panel (no upturned edges). Efficient and quick installation. Panel drops into ceiling grid and secured in place with snap-on hold down clip.
- Application:** Ceiling provided for interior installation. (See AC-110C for curved application)
- Material:** Panels are available in aluminum, steel or stainless steel.
- Finishes:** Painted powder coat colors, anodized, brushed and bright, simulated wood grain veneer, real wood veneer or custom finishes. Reference Options tab for available finishes.
- Standard Sizes:** 24" x 24", 24" x 48", Custom sized panels also available.
- Fire Rating:** Class A
- Acoustics:** NRC rating of .70 to 1.00 can be achieved by selecting correct perforation pattern and acoustical backing.
- Perforation:** Reference Options Tab for Patterns, consult manufacturer for acoustical values
- Recycled content:** Aluminum alloys - 32% (5052) - 66% (3105)

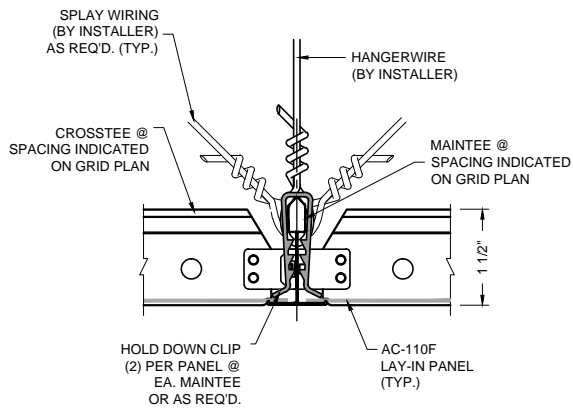

**1** PANEL JOINT DETAIL  
AC-110F-PJ1

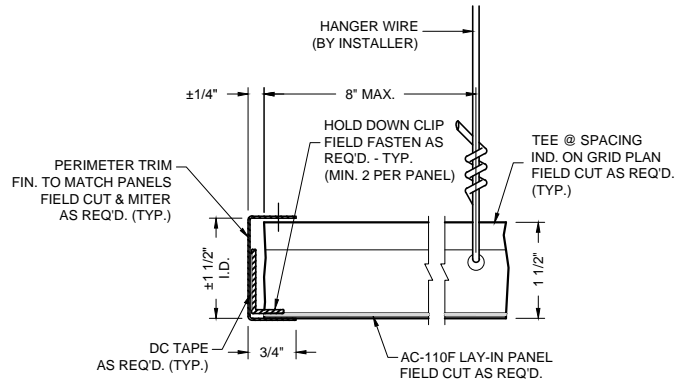

**2** PERIMETER DETAIL  
AC-110F-PFC2

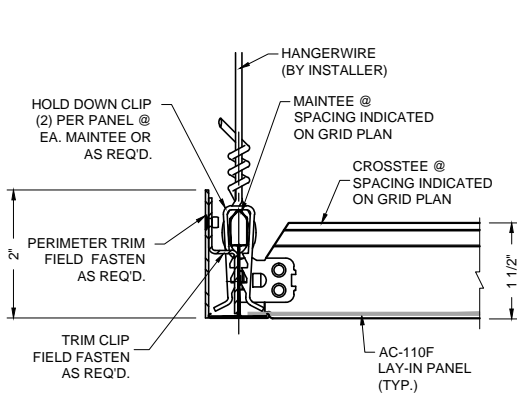

**3** PERIMETER DETAIL  
AC-110F-P2

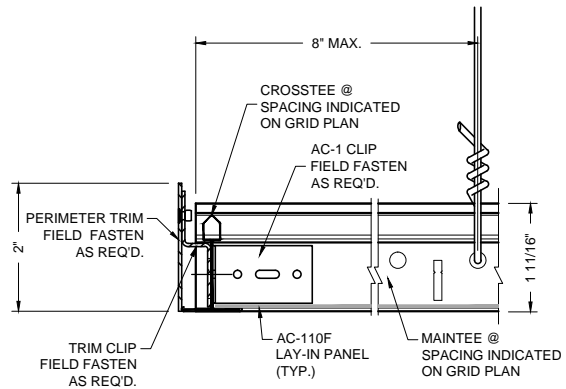

**4** PERIMETER DETAIL  
AC-110F-P3

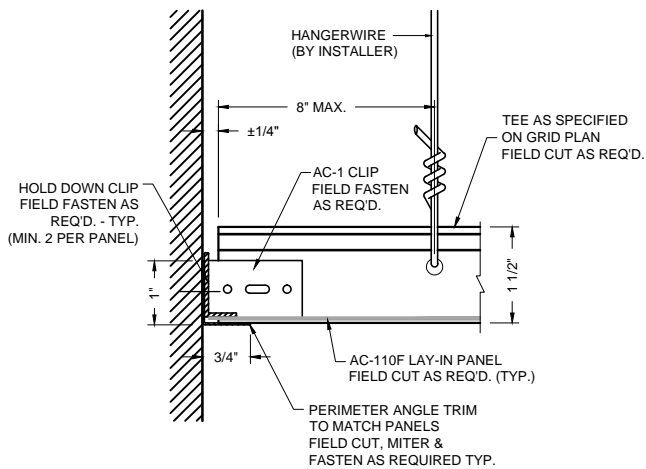

**5** PERIMETER DETAIL  
AC-110F-PFC1