

accent

CEILINGS AND WALLS

A DIVISION OF ADAMS CAMPBELL COMPANY
ISO 9001: 2000 CERTIFIED

METAL HOOK ON WALL PANEL SYSTEM (AC-750)

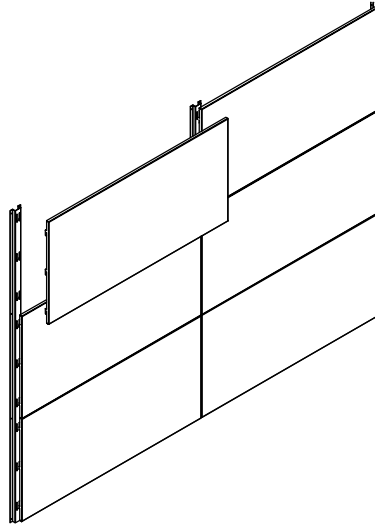

- Description:** Factory formed metal panels with formed edges all four sides (1.00", 2.00", 3.00" and 4.00" formed edges available), Perforated or Non-Perforated. Panels edges have laser cut support tabs that are an integral part of the panel edge. Tabs inserted into wall mounted vertical hat channel slots. Perimeter trim available for field cut conditions.
- Application:** Wall panel provided for interior installation. Curved application available.
- Material:** Panel available in aluminum, steel or stainless steel
- Finishes:** Painted powder coat colors, brushed, bright, anodized, vinyl or custom finishes
Reference Options tab for available finishes.
- Mounting:** Vertical hat channel is factory fabricated with slots for panel installation. Reveal joints horizontal hat channel is provided at all horizontal panel joints
- Joints:** Butt joint and reveal joint conditions available.
- Standard Sizes:** Maximum size 4'-0" x 10'-0"
- Fire Rating:** Class A
- Acoustics:** NCR rating of .70 to .100 can be achieved by selecting correct perforation pattern and acoustical backing.
- Perforation:** Reference Options Tab for Patterns, consult manufacturer for acoustical values
- Recycled content:** Aluminum 60% · Steel 33% · Stainless Steel 69%

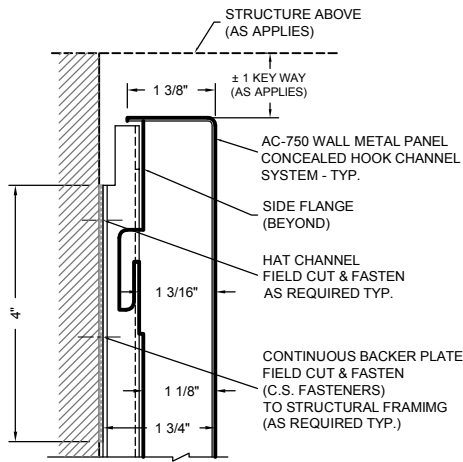

1 PERIMETER DETAIL (TOP)
AC-750-FT1

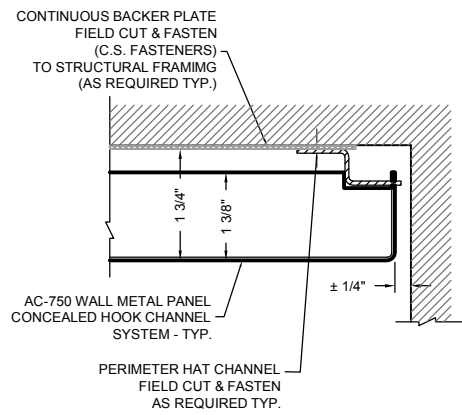

2 PERIMETER DETAIL
AC-750-FE1

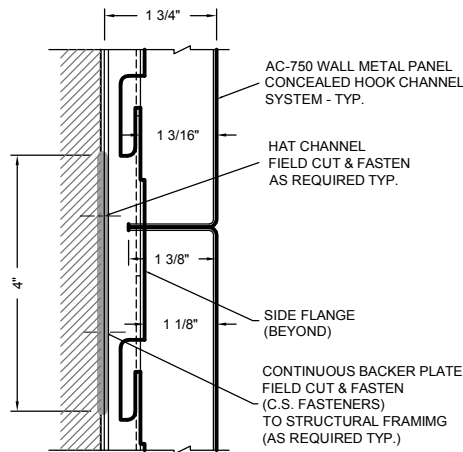

3 PANEL JOINT DETAIL
AC-750-FM1

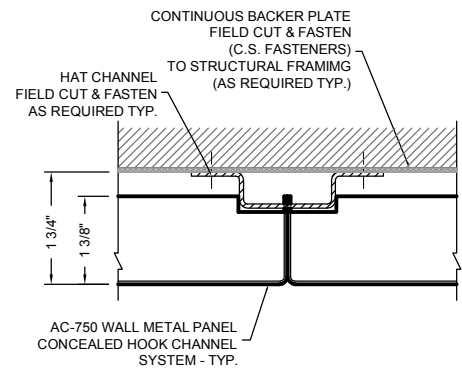

4 PANEL JOINT DETAIL
AC-750-FS1

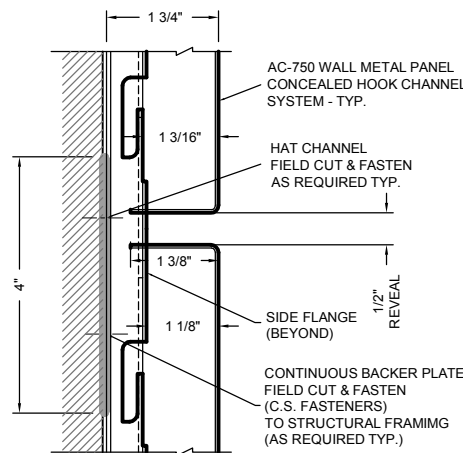

5 PANEL JOINT DETAIL
AC-750-FM2

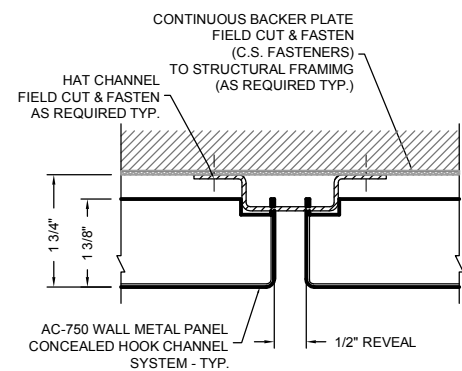

6 PANEL JOINT DETAIL
AC-750-FS2

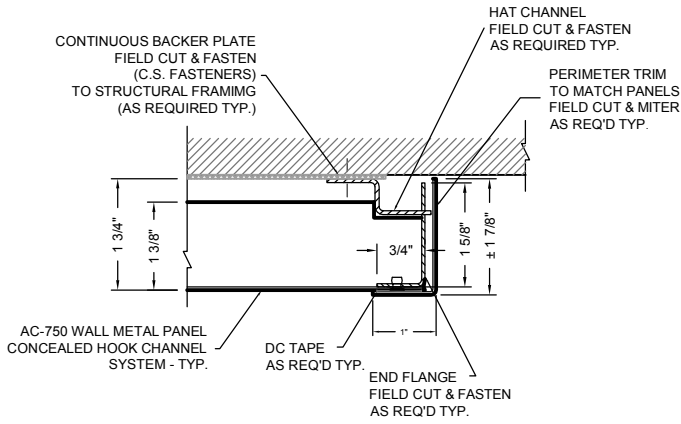

1 PERIMETER DETAIL
AC-750-FCE1

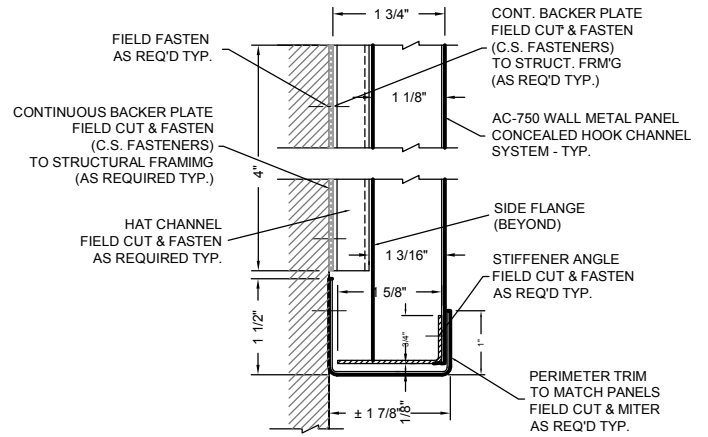

2 PERIMETER DETAIL (BASE)
AC-750-FB1

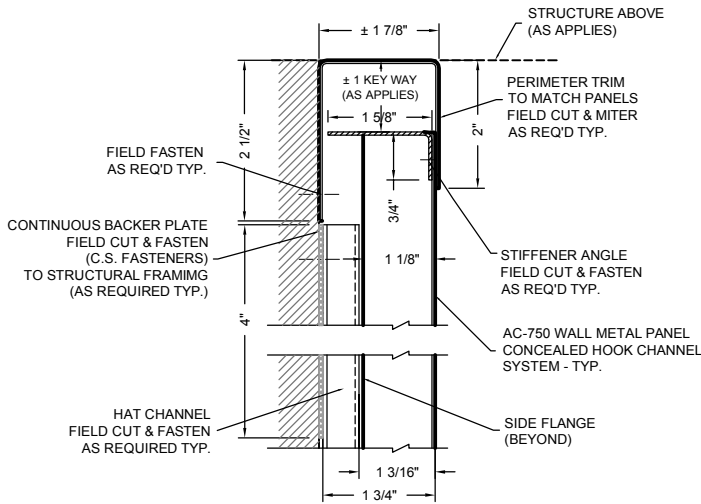

3 PERIMETER DETAIL
AC-750-FCT1

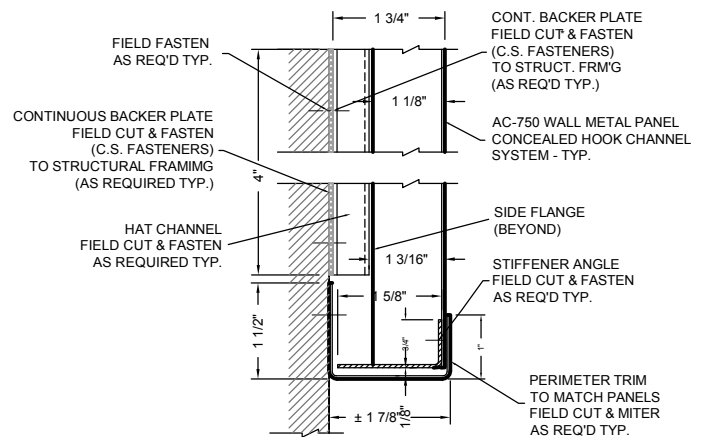

4 PERIMETER DETAIL (BASE)
AC-750-FCB1