

**accent**  
**CEILINGS AND WALLS**  
A DIVISION OF ADAMS CAMPBELL COMPANY  
ISO 9001: 2000 CERTIFIED

**SNAP-IN FLAT METAL CEILING SYSTEM (AC-310)**

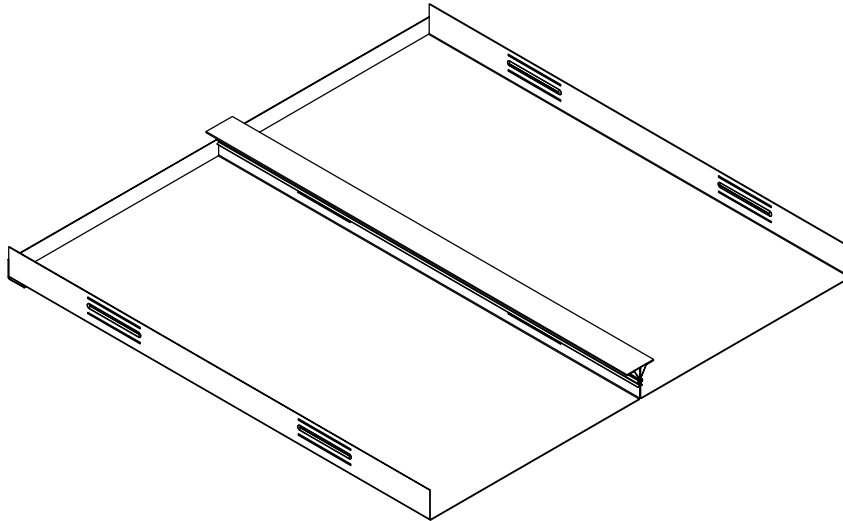

- Description:** Economical snap-in ceiling system, Perforated or Non-Perforated. Snap-in carrier is mounted directly to structure or other rigid backing. Efficient and quick installation.
- Application:** Ceiling provided for flat interior installation.
- Material:** Panel available in aluminum, steel or stainless steel
- Finishes:** Painted powder coat colors, brushed, bright, anodized, vinyl or custom finishes  
Reference Options tab for available finishes.
- Standard Sizes:** 24" x 24", 24" x 48" and 30" x 30". Custom sized panels also available.
- Fire Rating:** Class A
- Acoustics:** NCR rating of .70 to .100 can be achieved by selecting correct perforation pattern and acoustical backing.
- Perforation:** Reference Options Tab for Patterns, consult manufacturer for acoustical values
- Recycled content:** Aluminum 60% · Steel 33% · Stainless Steel 69%

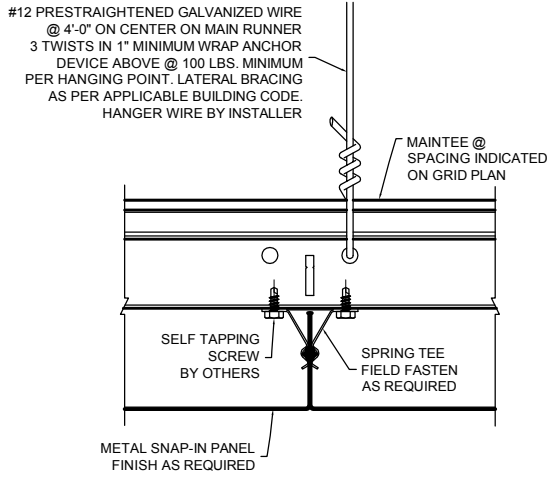

# 1 PANEL JOINT DETAIL

AC-310-PJ1

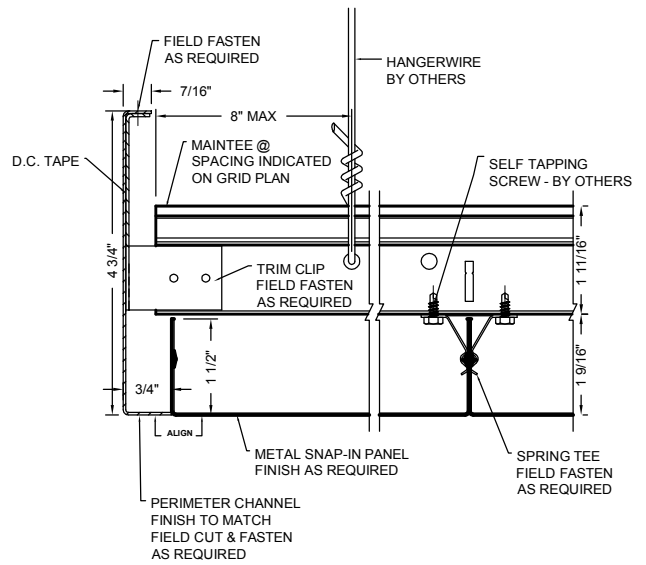

# 2 PERIMETER DETAIL

AC-310-P1

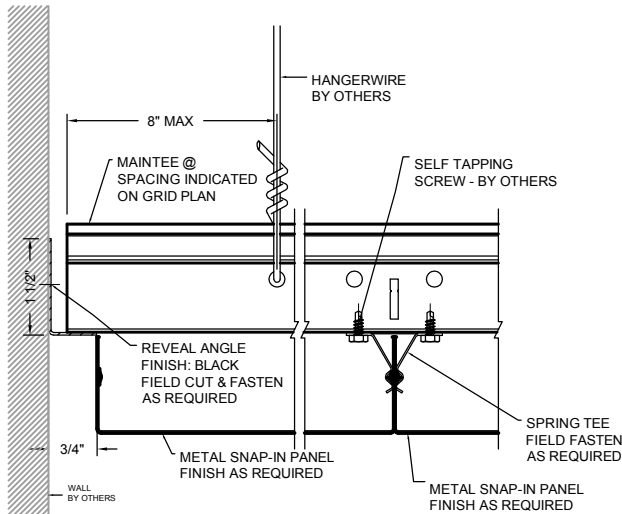

# 3 PERIMETER DETAIL

AC-310-P2

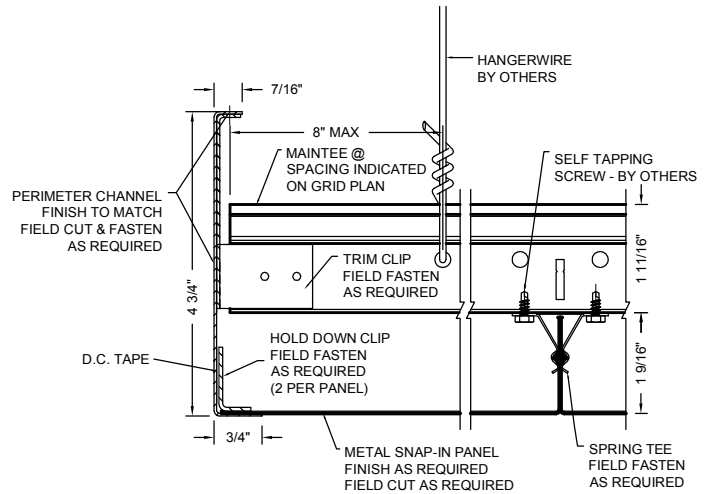

# 4 PERIMETER DETAIL

AC-310-PFC1

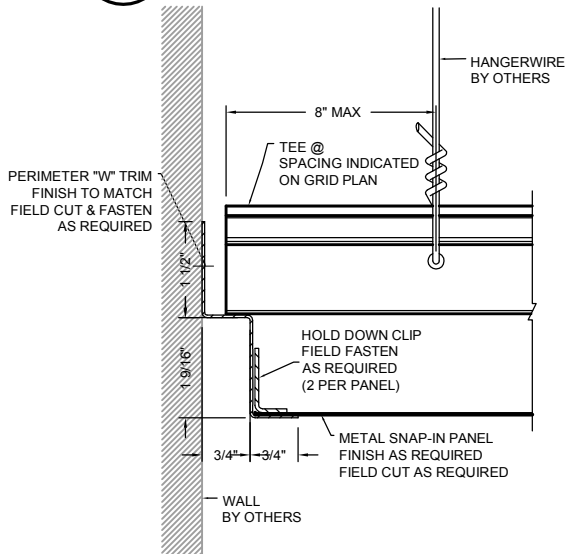

# 5 PERIMETER DETAIL

AC-310-PFC2